

NOTICE: This document contains references to Varian. Please note that Varian, Inc. is now part of Agilent Technologies. For more information, go to [www.agilent.com/chem](http://www.agilent.com/chem).



# ***Instructions for Varian Gauge Cable Connector Kits***

*FIELD INSTALLATION  
INSTRUCTIONS*

Part Number 699908080  
Rev. C  
July 2006

# Varian Field Instruction Sheet

## Instructions for Varian Gauge Cable Connector Kits

### Preface

#### Documentation Standards

This manual uses the following documentation standards:

#### NOTE



Notes contain important information.

#### CAUTION



Cautions appear before instructions, which if not followed, could cause damage to the equipment or data loss.

#### WARNING



Warnings appear for a particular procedure or practice which, if not followed correctly, could lead to serious injury or death.

#### Hazard and Safety Information

The common international symbols used in this manual and on the equipment are defined below.



OFF Supply (Power)



ON Supply (Power)



AC – Alternating Current



Warning, Risk of danger



Frame or chassis Terminal



Earth (Ground) Terminal



Caution, Hot Surface



Caution, Risk of Electrical Shock



Protective Conductor Terminal



This sheet provides instructions for terminating Varian supplied gauge cables for the UHV24, Glass BA, IMG-100, UHV-IMG, and Convectorr gauges in the field. Only the use of Varian supplied cable guarantees proper fit and performance. All connector kits consist of the connector housings, contacts, ferrite beads, as required, and the miscellaneous hardware required to make up Multigauge or Sentorr cables in the field.

**Instructions L6440ConnKit for UHV24 and UHV24P**

The connector kit consists of a connector housing molded of high temperature and radiation resistant material, contacts for crimping onto the cable wires, and miscellaneous hardware. This kit is only suitable for 18AWG wire and RG-187A coax. (Varian P/Ns: L6440BakCable50, L6440RadCable50, and L6455Cable100)

**NOTE**



**18AWG cable is only suitable for use for lengths up to 50'. For lengths longer than 50', use cable P/N: L6456Cable100 with no more than 10' of L6455Cable100.**

The contacts used for each connector are packaged with the connector.

To install:

1. Wire the connectors as in Figure 1: UHV24 and UHV24P Wiring.

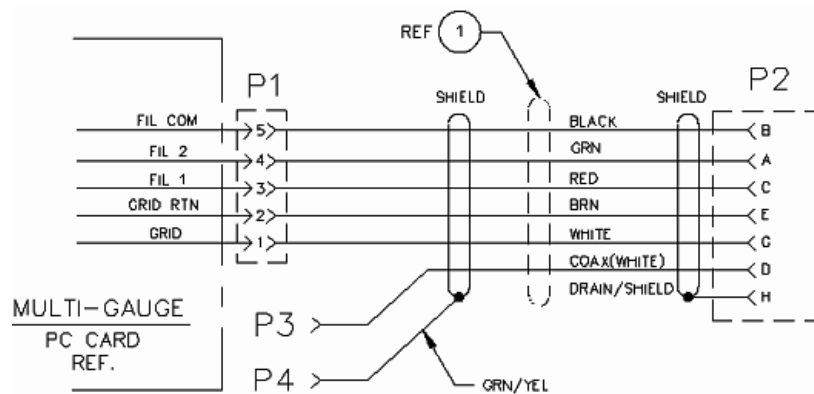

**Figure 1: UHV24 and UHV24P Wiring**

2. Install the ferrite beads.

**CAUTION**



**Failure to install the ferrite beads leads to erroneous readings and excessive EMI radiation.**

3. Assemble connectors P1, P3 and P4 as shown in Figure 2: P1, P3 and P4 Connectors.

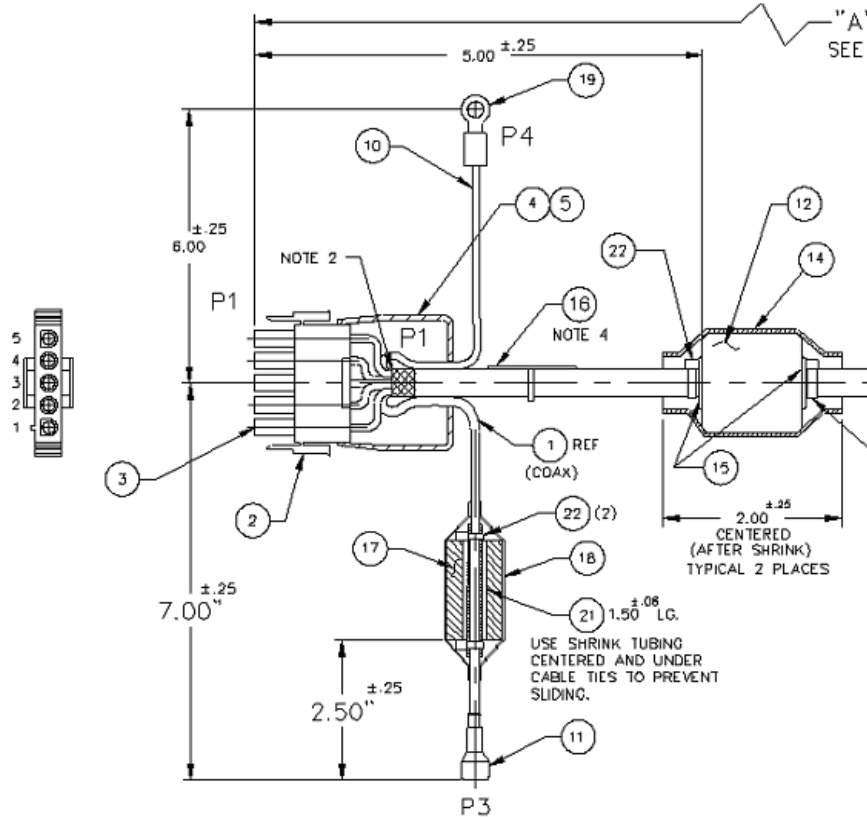

Figure 2: P1, P3 and P4 Connectors

**NOTE**

The Yel/Grn wire is soldered to the cable shield.



4. Assemble connector P2 is shown in Figure 3: P2 Connector - Preparation and "Figure 4: P2 Connector - Wiring" on page 4.

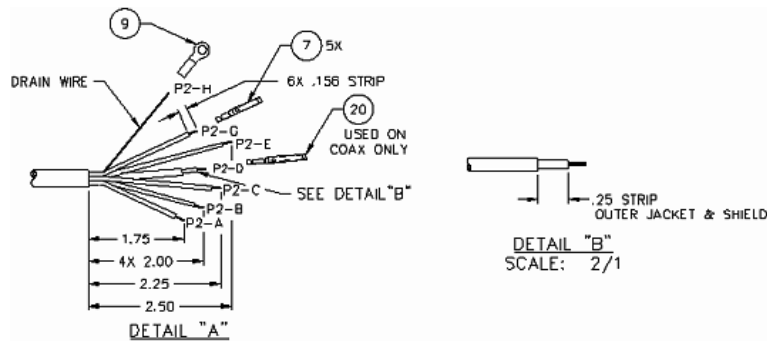
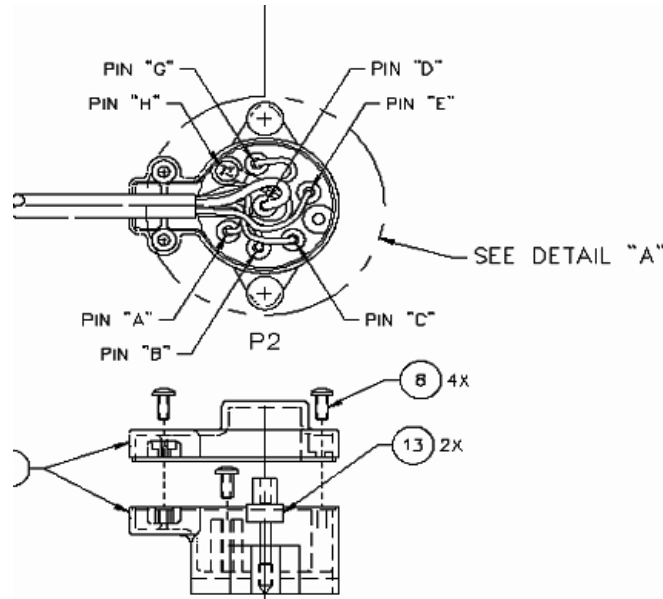

Figure 3: P2 Connector - Preparation

**NOTE**



**Item 9 is not used. Cut the drain wire flush.**



**Figure 4: P2 Connector - Wiring**

**Instructions for L6455ConnKit for all Glass BA gauges**

The connector kit consists of a connector housing molded of high temperature and radiation resistant material, contacts for crimping onto the cable wires, and miscellaneous hardware. This kit is only suitable for 18AWG wire and RG-187A coax. (Varian P/N: L6455Cable100)

**NOTE**



**18AWG cable is only suitable for use for lengths up to 50'. For lengths longer than 50', use cable P/N: L6456Cable100 with no more than 10' of L6455Cable100.**

The contacts used for each connector are packaged with the connector.

To install:

1. Wire the connectors as in Figure 5: Glass BA Gauges Wiring.

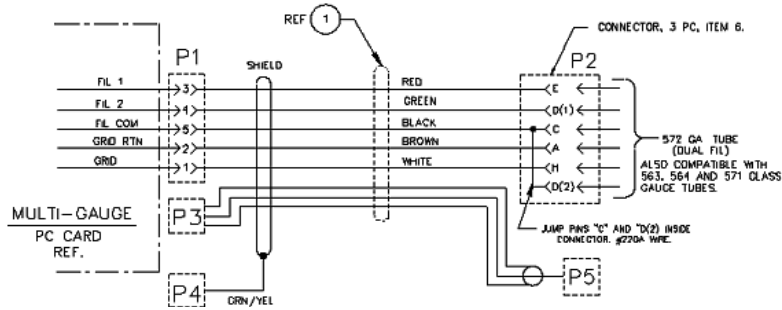

Figure 5: Glass BA Gauges Wiring

2. Install the ferrite beads.

**CAUTION**



Failure to install the ferrite beads leads to erroneous readings and excessive EMI radiation.

3. Assemble connectors P1, P3 and P4 as shown in Figure 6: P1, P3 and P4 Connectors.

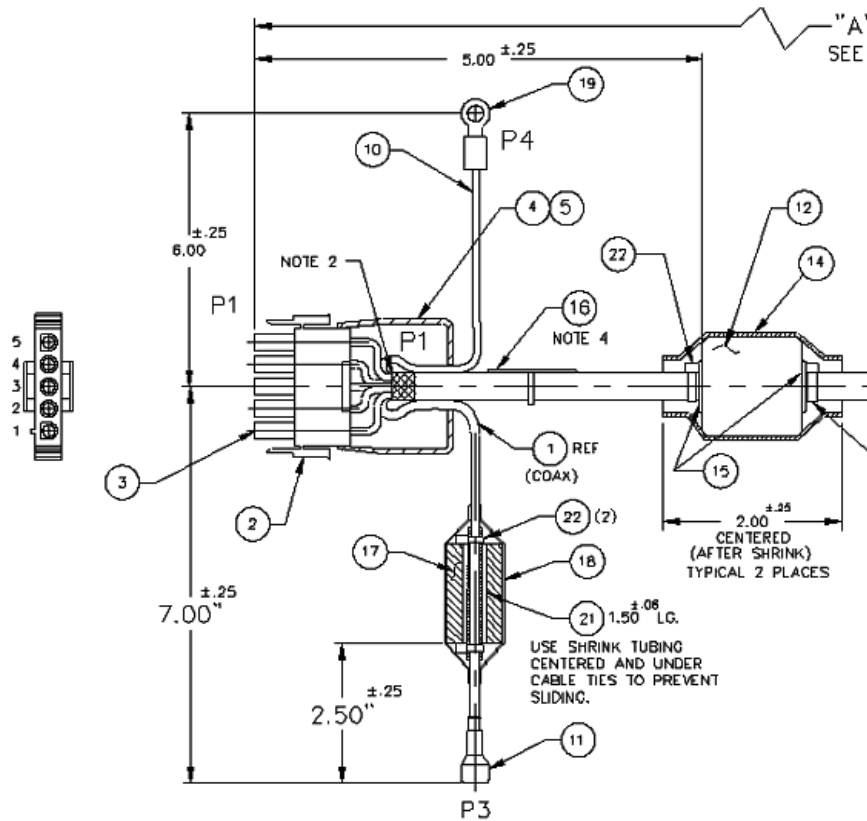

Figure 6: P1, P3 and P4 Connectors

**NOTE**

The Yel/Grn wire is soldered to the cable shield.



4. Assemble connector P2 is shown in Figure 7: P2 Connector - Preparation and Figure 8: P2 Connector - Wiring.

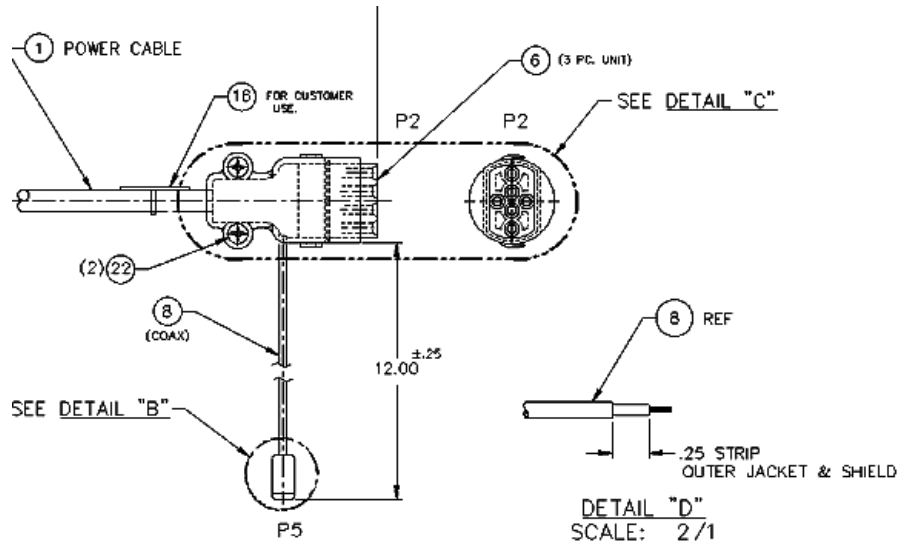

**Figure 7: P2 Connector - Preparation**

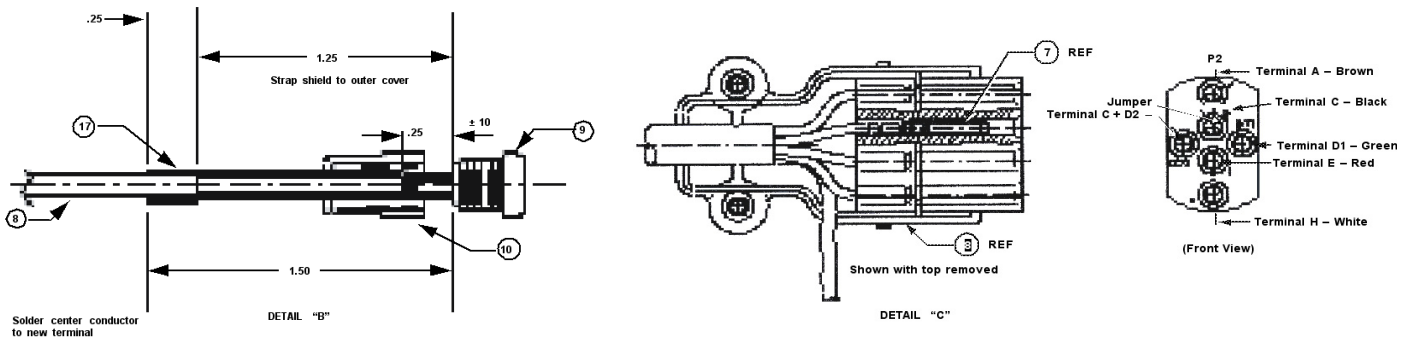

**Figure 8: P2 Connector - Wiring**

## Instructions for L6456ConnKit for BA/UHV Extension Cable

This kit includes the connectors and contacts required to terminate glass and UHV type BA gauge extension cable for lengths over 50' and is used with standard cable of no more than 10'. This kit is only suitable for 12AWG wire and RG-187A coax. (Varian P/N: L6456Cable100).

### NOTE



**18AWG cable is only suitable for use for lengths up to 50'. For lengths longer than 50', use cable P/N: L6456Cable100 with no more than 10' of L6456Cable100.**

The contacts used for each connector are packaged with the connector.

To install:

1. Wire the connectors as in Figure 9: B/A and UHV Extension Wiring.

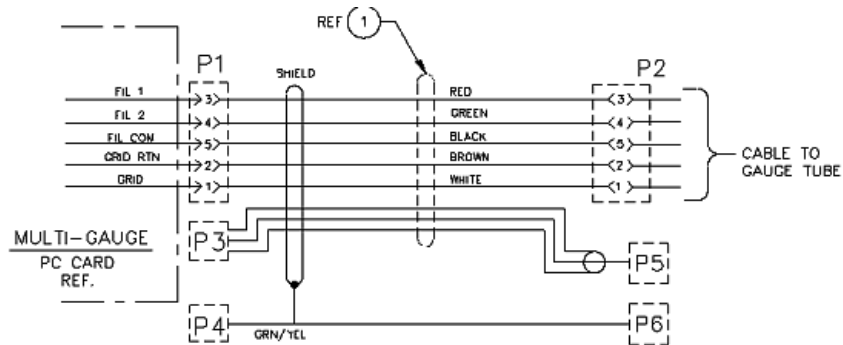

Figure 9: B/A and UHV Extension Wiring

2. Install the ferrite beads.

### CAUTION



**Failure to install the ferrite beads leads to erroneous readings and excessive EMI radiation.**



3. Assemble connectors P1, P3 and P4 as shown in Figure 10: P1, P3 and P4 Connectors.

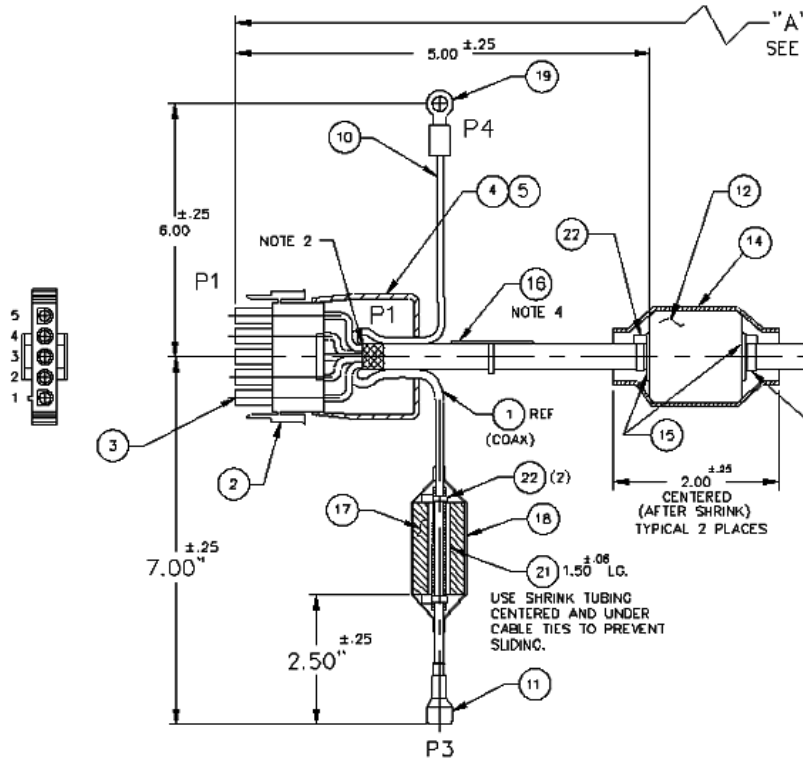

Figure 10: P1, P3 and P4 Connectors

NOTE

The Yel/Grn wire is soldered to the cable shield.



4. Assemble connector P2 is shown in Figure 11: P2, P5 and P6 Connectors.

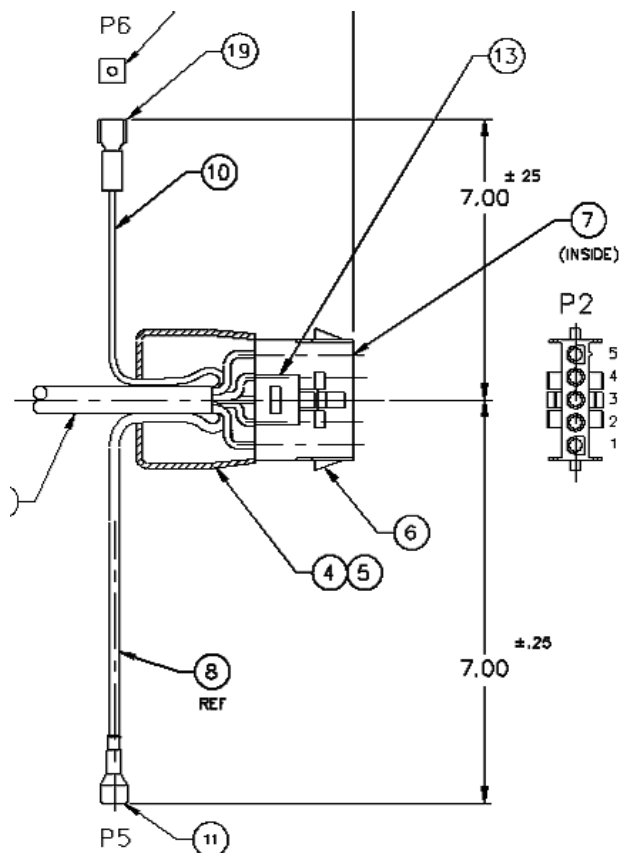

Figure 11: P2, P5 and P6 Connectors

## Instructions for L9122ConnKit for Convectorr Gauge

This kit includes the connectors and contacts required to terminate Convectorr gauge cables. This kit is only suitable for 20AWG wire shielded wire. (Varian P/N: L9122Cable100, L9122Cable250).

The contacts used for each connector are packaged with the connector.

To install:

1. Wire the connectors as per Figure 12: Convectorr Gauge Wiring.

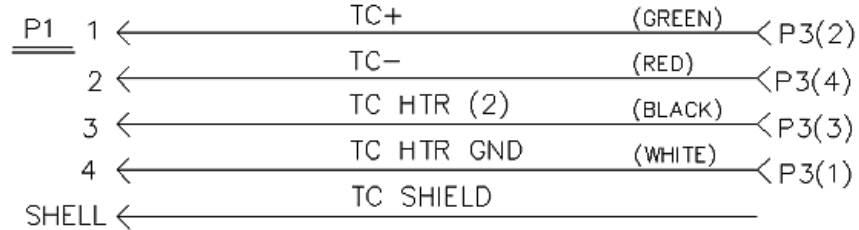

**Figure 12: Convectorr Gauge Wiring**

### CAUTION



**Failure to install the ferrite beads leads to erroneous readings and excessive EMI radiation.**

2. Assemble connectors P1 and P3 as per Figure 13: P1 and P3 Connectors - Wiring. Ensure that the drain wire is soldered to the P1 housing.

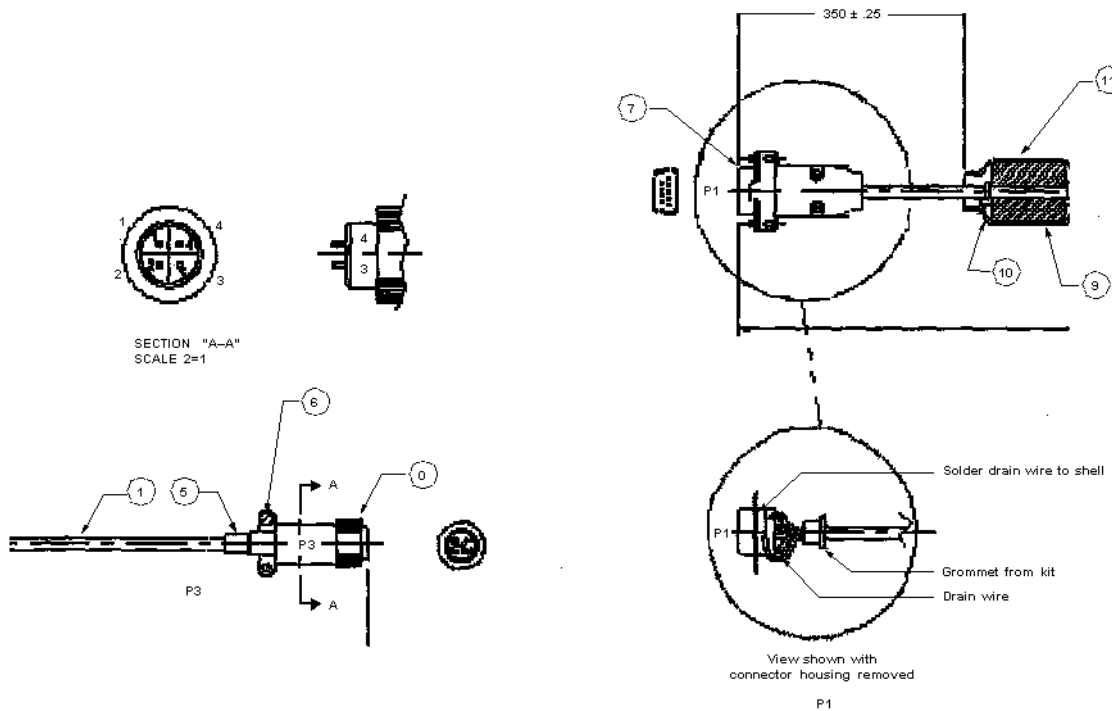

**Figure 13: P1 and P3 Connectors - Wiring**

## Instructions for L9131ConnKit for Thermocouple Gauge

This kit includes the connectors and contacts required to terminate the thermocouple gauge cables use with the Sentorr and Multigauge Convectorr cards. This kit is only suitable for 20AWG wire shielded wire. (Varian P/N: L9122Cable100, L9122Cable250).

The contacts used for each connector are packaged with the connector.

To install:

1. Wire the connectors as per Figure 14: Sentorr and Multigauge Convectorr Thermocouple Gauge Wiring.

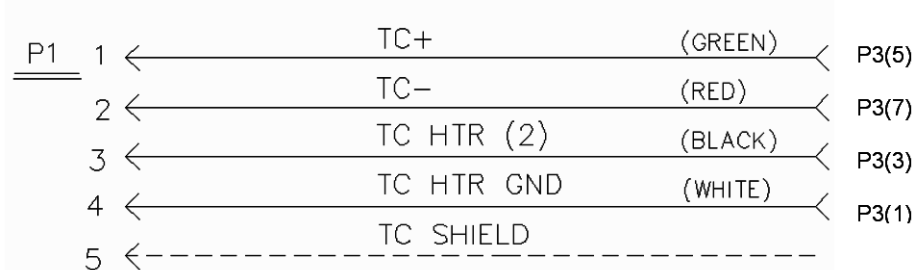

**Figure 14: Sentorr and Multigauge Convectorr Thermocouple Gauge Wiring**

### CAUTION



**Failure to install the ferrite beads leads to erroneous readings and excessive EMI radiation.**

2. Assemble connectors P1 and P3 as per Figure 15: P1 Connector - Wiring and "Figure 16: P3 Connector - Wiring" on page 12. Ensure that the drain wire is soldered to the P1 housing.

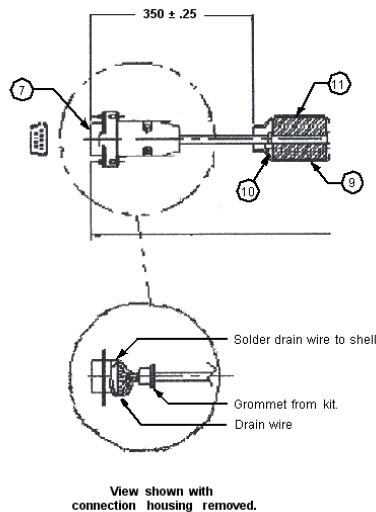

**Figure 15: P1 Connector - Wiring**

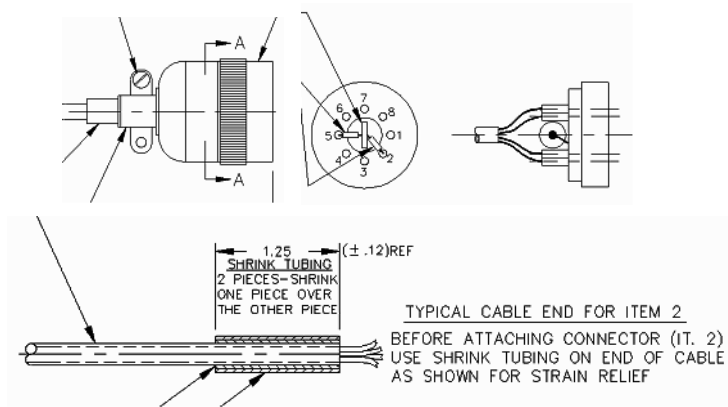

**Figure 16: P3 Connector - Wiring**

### Instructions for R0341ConnKit for IMG Gauge Cable

This kit includes the connectors and contacts required to terminate both bake-able and non-bake-able IMG gauge cables. This kit is only suitable for RG/U-59U (Teflon bake-able) and RG/U-58A (PVC non-bake-able) coax cable.

The contacts used for each connector are packaged with the connector.

To install:

- Wire the connectors as per Figure 17: IMG Cable Wiring. Use the Tyco-Amp Certi-Crimp tool # 220022-1 to assemble these connectors to the cable. Instructions can be found at:

<http://ecommas.tycoelectronics.com/commerce/DocumentDelivery/DDEController>

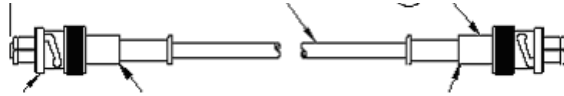

Figure 17: IMG Cable Wiring

## Sales and Service Offices

### Canada

#### Central coordination through:

Varian, Inc.  
121 Hartwell Avenue  
Lexington, MA 02421  
USA  
Tel: (781) 861 7200  
Fax: (781) 860 5437  
Toll Free: (800) 882 7426

### China

#### Varian Technologies - Beijing

Room 1201, Jinyu Mansion  
No. 129A, Xuanwumen Xidajie  
Xicheng District  
Beijing 1000031  
P.R. China  
Tel: (86) 10 6608 1031  
Fax: (86) 10 6608 1541

### France and Benelux

#### Varian s.a.

7 avenue des Tropiques  
Z.A. de Courtaboeuf – B.P. 12  
Les Ulis cedex (Orsay) 91941  
France  
Tel: (33) 1 69 86 38 13  
Fax: (33) 1 69 28 23 08

### Germany and Austria

#### Varian Deutschland GmbH

Alsfelder Strasse 6  
Postfach 11 14 35  
64289 Darmstadt  
Germany  
Tel: (49) 6151 703 353  
Fax: (49) 6151 703 302

### India

#### Varian India PVT LTD

101-108, 1st Floor  
1010 Competent House  
7, Nangal Raya Business Centre  
New Delhi 110 046  
India  
Tel: (91) 11 5548444  
Fax: (91) 11 5548445

### Italy

#### Varian, Inc.

Via F.Ili Varian, 54  
10040 Leini, (Torino)  
Italy  
Tel (39) 011 997 9 111  
Fax (39) 011 997 9 350

### Japan

#### Varian, Inc.

Sumitomo Shibaura Building, 8th Floor  
4-16-36 Shibaura  
Minato-ku, Tokyo 108  
Japan  
Tel: (81) 3 5232 1253  
Fax: (81) 3 5232 1263

### Korea

#### Varian Technologies Korea, Ltd.

Shinsa 2nd Building 2F  
966-5 Daechi-dong  
Kangnam-gu, Seoul  
Korea 135-280  
Tel: (82) 2 3452 2452  
Fax: (82) 2 3452 2451

### Mexico

#### Varian S.A.

Concepcion Beistegui No 109  
Col Del Valle  
C.P. 03100  
Mexico, D.F.  
Tel: (52) 5 523 9465  
Fax: (52) 5 523 9472

### Russia

#### Central coordination through:

Varian, Inc.  
via F.Ili Varian 54  
10040 Leini, (Torino)  
Italy  
Tel: (39) 011 997 9 252  
Fax: (39) 011 997 9 316

### Taiwan

#### Varian Technologies Asia Ltd.

18F-13 No.79, Hsin Tai Wu Road  
Sec. 1, Hsi Chih, Taipei Hsien  
Taiwan, R.O.C.  
Tel: (886) 2 2698 9555  
Fax: (886) 2 2698 9678

### UK and Ireland

#### Varian Ltd.

28 Manor Road  
Walton-On-Thames  
Surrey KT 12 2QF  
England  
Tel: (44) 1932 89 8000  
Fax: (44) 1932 22 8769

### United States

#### Varian, Inc.

121 Hartwell Avenue  
Lexington, MA 02421  
USA  
Tel: (781) 861 7200  
Fax: (781) 860 5437

### Other Countries

#### Varian, Inc.

Via F.Ili Varian 54  
10040 Leini, (Torino)  
Italy  
Tel: (39) 011 997 9 111  
Fax: (39) 011 997 9 350

### Customer Support and Service:

#### North America

Tel: 1 (800) 882-7426 (toll-free)  
vtl.technical.support@varianinc.com

#### Europe

Tel: 00 (800) 234 234 00 (toll-free)  
vtl.technical.support@varianinc.com

#### Japan

Tel: (81) 3 5232 1253 (dedicated line)  
vtj.technical.support@varianinc.com

#### Korea

Tel (82) 2 3452 2452 (dedicated line)  
vtk.technical.support@varianinc.com

#### Taiwan

Tel: 0 (800) 051 342 (toll-free)  
vtw.technical.support@varianinc.com

### Worldwide Web Site, Catalog and On-line Orders:

[www.varianinc.com](http://www.varianinc.com)

Representatives in most countries



**VARIAN**