

COBRA NC 0400-1000 B/C

Dry screw vacuum pumps



VACUUM SOLUTIONS



High performance

Advanced screw design, patented self-balancing screws, perfectly suited for chemical processes, distillation and vacuum drying

Efficient

Low cost of ownership, minimal maintenance, long service intervals, high uptime, efficient water cooling

Flexible

Air cooling, various sealing and coating configurations as well as ATEX-certified versions available

Accessories

- Various sealing and coating configurations
- ATEX-certified versions available

COBRA NC 0400-1000 B/C

Dry screw vacuum pumps



VACUUM SOLUTIONS

Dimensional drawing

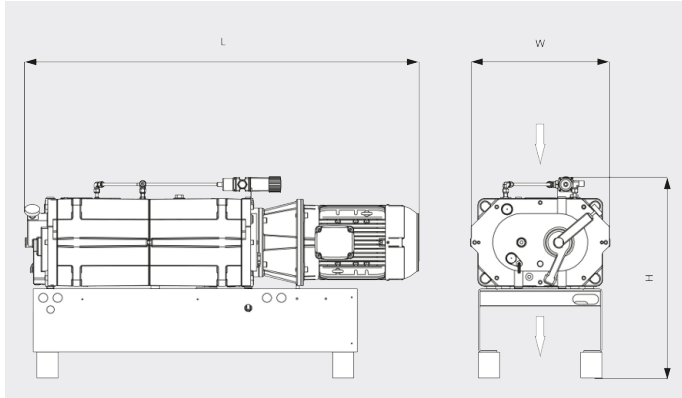

Pumping speed

Air at 20°C. Tolerance: ± 10%

— 50 Hz 60 Hz

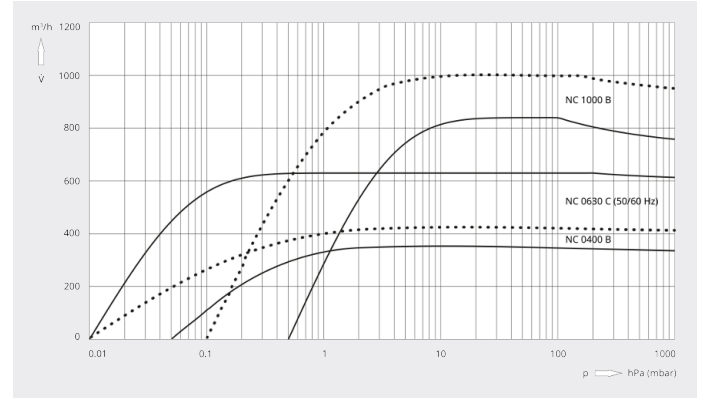

	COBRA NC 0400 B	COBRA NC 0630 C	COBRA NC 1000 B
Pumping speed	247 ACFM	371 ACFM	590 ACFM
Ultimate pressure	≤ 0.0075 TORR	≤ 0.0075 TORR	≤ 0.0075 TORR
Nominal motor rating	15 HP	20 HP	40 HP
Nominal motor speed	3600 RPM	3600 RPM	3600 RPM
Noise level (ISO 2151)	69 dB(A)	75 dB(A)	81 dB(A)
Weight approx.	1433 Lbs.	1645 Lbs.	3050 Lbs.
Dimensions (L x W x H)	71.5 x 23.6 x 30.7 inches	71.3 x 29.9 x 30.4 inches	92 x 35.1 x 42.9 inches
Gas inlet / outlet	3" ANSI/NPT / 3" ANSI/NPT	3" ANSI/NPT / 3" ANSI/NPT	5" ANSI/NPT / 5" ANSI/NPT

DO YOU WANT TO KNOW MORE?

Get in touch with us directly!
info@buschusa.com or +1 757 463 7800



CONTACT FORM



CALL NOW

12 Technical Data

		WV 0250 C	WV 0500 C	WV 1000 C	WV 1500 C	WV 2000 C
Nominal pumping speed (50Hz / 60Hz)	m ³ /h	250 / 300	500 / 600	1000 / 1200	1500 / 1800	2000 / 2400
Nominal motor rating (50Hz / 60Hz)	kW	1.1 / 1.2	2.2 / 3.0	3.5 / 4.8	4.2 / 5.5	6.0 / 7.6
Nominal motor speed (50Hz / 60Hz)	min ⁻¹	1500 / 1800	3000 / 3600	3000 / 3600	3000 / 3600	3000 / 3600
Ambient temperature range	°C	5 ... 40				
Max. gas inlet temperature	°C	200 (P <10 hPa, staging ratio of 4)				
Relative humidity	at 30°C	90%				
Oil capacity (Motor side)	l	0.4	0.4	0.7	0.7	1.65
Oil capacity (Gear side)	l	0.5	0.5	1.2	1.2	3
Oil capacity (Oiler)	l	0.35	0.35	0.5	0.5	0.25
Weight approx.	kg	146	146	256	270	546

13 Oil

	VE 101	VSL 100
ISO-VG	100	100
Part number 1 L packaging	0831 000 099	0831 122 573
Part number 5 L packaging	0831 000 100	0831 122 572

To know which oil has been filled in the machine, please refer to the nameplate (NP).